



R10

User's Guide

Empulse

R10000

www.sunrisemedical.com

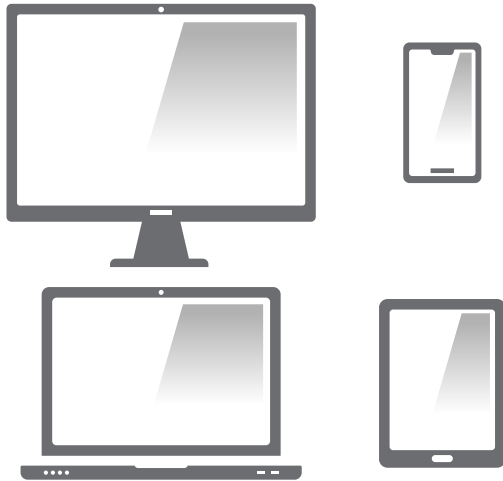

If you are visually impaired, this document can be viewed in PDF format at www.sunrisemedical.co.uk or alternatively is available on request in large text.

Components of the pushing device

We at SUNRISE MEDICAL have been awarded the ISO-13485 certificate, which affirms the quality of our products at every stage, from R & D to production. This product complies with the standards set forth in EU and UK regulations.



Table of contents

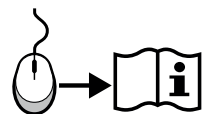







R10 pushing device

1. Drive wheel
2. Mudguard
3. Docking arm
4. Backpack with battery and controller
5. Control unit

Contents

1. Definitions	3
2. Foreword	4
3. Use	5
4. Area of application:.....	5
5. General safety notes and driving limits	6
6. Safety instructions – prior to each ride	7
7. Safety instructions – while driving	7
8. Warranty	8
9. Delivery	9
10. Docking Information	10
11. Starting up	11
11.1 Install the push device to the wheelchair	11
11.2 Install battery	12
11.2.1 Fitting the backpack onto the wheelchair..	12
11.3 Mounting the rear controller unit	13
11.4 Connecting cables	13
11.5 Run R10	14
12. Battery/Charge	14
12.1 Charging the batteries:	15
12.2 Safety information and precautions on how to transport and ship the battery.....	16
13. Transportation	17
14. Safety	18
15. Maintenance.....	18
16. Frequency of Service	19
17. Tyre maintenance	19
18. Cleaning/Hygiene	20
19. Disposal / Recycling of materials	20
20. Name plate	21
21. Torque	22
22. Technical data.....	23
23. Problem solving	24

1. Definitions

Word	Definition
 DANGER!	Advice to the user of Potential Risk of serious injury or death if the advice is not followed.
 WARNING!	Advice to the user of a potential risk of injury if the advice is not followed.
 CAUTION!	Advice to user that potential damage to equipment may occur if the advice is not followed.
 NOTE:	General advice or best practice.
	Reference To Additional Documentation.
	Does not fit.

NOTE:

Please keep a note of your local service agent's address and telephone number in the space provided. In the event of a breakdown, contact them and try to give all relevant details so they can help you quickly.

The pushing device shown and described in this user guide may not correspond in every detail exactly to your own model. However, all instructions are completely relevant, regardless of possible detail differences. The manufacturer reserves the right to alter without notice any weights, measurements or other technical data shown in this manual. All figures, measurements and capacities shown in this manual are approximate and do not constitute specifications.

Dealer signature and stamp

2. Foreword

Dear Customer,

We are very pleased that you have decided in favor of a high-quality SUNRISE MEDICAL product. This user's manual will provide numerous tips and ideas so that your new pushing device can become a trustworthy and reliable partner in your life.

For Sunrise Medical, it is very important that we have a good relationship with our customers. We like to keep you up-to-date about new and current developments at our company.

Keeping close to our customers means: fast service, as little red tape as possible, working closely with customers. When you need replacement parts or accessories, or if you just have a question about your pushing device – we are there for you. We want you to be satisfied with our products and service.

At Sunrise Medical we are constantly working to develop our products further. For this reason, changes can occur in our range of products regarding form, technology, and equipment. Consequently, no claims can be construed from the data or pictures contained in this user's manual.

The management system of SUNRISE MEDICAL is certified to EN ISO 9001, ISO 13485 and ISO 14001.

NOTE:

General user advice.

Not following these instructions may result in physical injury, damage to the product or damage to the environment!

Notice to the user and/or patient: Any serious incident that has occurred in relation to the device should be reported to the manufacturer and the competent authority of the Member State in which the user and/or patient is established.

Please contact your local, authorised SUNRISE MEDICAL dealer if you have any questions regarding the use, maintenance or safety of your pushing device. In case there is no authorised dealer in your area, or you have any questions about product safety and product recalls, contact Sunrise Medical either in writing or by telephone.

Sunrise Medical Australia
11 Daniel Street
Wetherill Park NSW 2164
Australia
Ph: +61 2 9678 6600
E: enquiries@sunrisemedical.com.au
www.SunriseMedical.com.au



Do not use your pushing device until you have read and understood this manual! Please follow the instructions contained within this Owner's Manual.

3. Use

The Empulse R10 is a powered pushing device, which is attached to a wheelchair, to support the mobility and integration of the wheelchair user in daily life.

The pushing device is designed for personal use indoors or outdoors by an attendant. Under no circumstances should the wheelchair user operate the pushing device themselves like a wheelchair power drive.

Attention: For safety reasons the attendant must have received training in how to handle the device from a dealer and must be physically and mentally capable of operating the device in all operating situations.

The maximum user weight is marked on the name plate with the serial number. The serial number label is located on the pushing device.

Warranty can only be taken on if the product is used under the specified conditions and for the intended purposes.

Lifespan

The expected life of the pushing device is 5 years, provided that:

- It is used in strict accordance with the intended use. When operating the pushing device, the values specified by the manufacturer of your wheelchair (for example the maximum slope, the air pressure in the tyres and other specifications), as well as the general operating instructions must be followed precisely and never exceeded.
- All service and maintenance requirements are fulfilled.
- A dealer training course has taken place

DANGER!

Do not fit any unauthorized electronic equipment. Any combination with other medical devices requires approval directly from Sunrise Medical or the manufacturer.

Do not fit any other devices without prior approval, as these could alter the intended use or the structure of the pushing device.

It is essential that you avoid starting up the pushing device before an authorised dealer has carried out a training course on the device!

NOTE:

Operating the pushing device may interfere with other equipment, for example anti-theft barriers in department stores. As the pushing device does not have a brake, we always recommend the use of drum brakes.

4. Area of application:

The pushing device provides the attendant with the potential to enable the user to safely cover long distances in an ergonomically and ecologically efficient manner, using their own wheelchair. It significantly extends the activity radius. The attached wheelchair must be equipped in accordance with road traffic regulations when used on public roads, pavements and spaces.

The max load (user and wheelchair) is 150kg.

The pushing device can be operated by people who:

- Are physically and mentally capable of safely operating the pushing device in all operating situations (uphill, downhill, etc.) and can meet the legal requirements for use on public roads.
- Have been advised and trained in its use by Sunrise Medical or an authorized Sunrise Medical dealer.

Operating Conditions

The pushing device should be able to cope with tarmac surfaces and firm paths with different topography. Avoid driving on loose surfaces (e.g. loose gravel, in sand, mud, snow, ice or through deep puddles of water), as this may expose the user to unforeseen risks.

Observe the information on permissible operating conditions in the Instructions for Use for the wheelchair onto which the pushing device is fitted. Any limits regarding the permissible operating conditions (e.g. maximum climbing capability, maximum permissible height of obstacles, max. user weight, etc.) must be observed when using the pushing device!

Indications

The adjustability, as well as the modular design, mean that it can be used by those who cannot walk or have limited mobility because of:

- Paralysis
- Loss of extremity (leg amputation)
- Extremity defect deformity
- Joint contractures/joint injuries
- Illnesses such as heart and circulation deficiencies, disturbance of equilibrium or cachexia as well as for elderly people who still have strength in the upper body.

Contraindications

The electrical pull- and add on devices shall not be used in case of:

- Perception disorder
- Imbalance
- Loss of both arms, if not supported by caregiver
- Joint contracture or joint damage on both arms
- Seating disability
- Physically and mentally not capable of safely operating the pulling device in all operating situations (steering, braking,..)
- Can't meet the legal requirements for use on public roads.

5. General safety notes and driving limits

The technology and construction of this pushing device have been designed to provide maximum safety. International safety standards currently in force have either been fulfilled or exceeded in parts.

Nevertheless, users may put themselves at risk by using their pushing device incorrectly. For your own safety, the following rules must be strictly observed.

Unprofessional or erroneous changes or adjustments increase the risk of accident. As a user of a pushing device, you are also part of the daily traffic on streets and pavements, just like anyone else. We would like to remind you that you are therefore also subject to any and all traffic laws. Be careful during your first ride in this pushing device. Familiarize yourself with the pushing device.

WARNING!

NEVER exceed the maximum user weight / max. load of 130 kg/150kg.

If the max user weight of the attached wheelchair is less than 130 kg, this lower limit will be valid for the complete system. Exceeding the maximum load can lead to damage to the pushing device, loss of control, or serious injury to the user and other people.

- It is essential that you take the user instructions for the wheelchair into account when using the pushing device.
- The wheel locks on the wheelchair to which the pushing device is fitted, must be located so that the attendant pushing the chair can reach them easily.
- Always exercise caution when using the pushing device and always start at the lowest speed level.

For example, avoid negotiating obstacles such as, steps, curbs, path edges or dropping down gaps without slowing down or braking first.

- Your pushing device has not been designed for transportation in a vehicle. When transporting in a vehicle, you must separate the pushing device from the wheelchair!!
- The pushing device should be used exclusively to convey one person at a time, with an attendant pushing. Any other use does not comply with the intended purpose. The pushing device may only be used by an attendant.
- Use of the pushing device is only recommended for those who have the appropriate physical and psychological constitution. The individual must be capable of holding the wheelchair and user when tipping backwards or to the side.
- We strongly recommend the use of anti-tips on the wheelchair. On gradients over 8%, two tipping supports are mandatory.
- As a beginner, you should ride particularly carefully at first.

- Familiarize yourself with the handling of the pushing device on level ground first, at the lowest speed level before you go up or down slopes. In order to be able to go up or down slopes safely, we strongly recommend the use of drum brakes.
- The speed of the pushing device must be adjusted to suit the technical capabilities of the wheelchair, terrain and the attendant. The maximum speed is 4.5km/h. Never exceed this maximum speed under any circumstances.
- At night and dawn/dusk, always use the lights.
- Only ride on asphalt paths, or firm, smooth surfaces.
- Never drive on slopes >8°. The maximum permissible slope as specified by the wheelchair manufacturer must not be exceeded under any circumstances.
- Use caution when riding over curbs, steps, potholes, etc. as there is an increased risk of tipping over. Never drive-up steps or go over pits with the power assist switched on.
- Adjust your method of driving to your capabilities.
- Ride slowly and carefully, particularly when riding round corners.
- Do not touch the motor, because it can get very hot.
- Your pushing device should be checked and serviced by your dealer at regular intervals (every two years).
- As with all moving parts, there is a risk that fingers could become trapped. Please always handle carefully.
- If the pushing device is subject to direct sunlight / low temperatures for long periods, parts could become very hot (>41°C) or very cold (<0°). This could cause the motor to heat up and in an extreme case, not be able to operate at full power. Even plastic parts age quicker under intense sunlight.
- Always make sure that the pushing device is properly and safely clicked into the receivers on the wheelchair frame and make sure that the receivers are positioned correctly. Make sure the quick-release axle for the motor wheel is positioned correctly.
- The pushing device should not be used in storm conditions, heavy rain/snow or on slippery or unpaved surfaces.
- The pushing device may interfere with other equipment, for example anti-theft barriers in department stores.
- In rare cases, the pushing aid can interfere with the operation of devices due to electromagnetic fields.
- In rare cases, electromagnetic fields can influence the driving performance of the pushing aid.

DANGER!

CHOKING HAZARD – This mobility aid uses small parts which under certain circumstances may present a choking hazard to small children.

6. Safety instructions – prior to each ride

CAUTION!

Check the condition of the pushing device and the wheels of your wheelchair (spokes and rims, damage to tyres) visually and check the tyre pressure.

Low tyre pressure increases the risk of tipping over especially in bends. It also affects the braking action, the wear and tear and the driving performance due to increased rolling resistance.

Always check that the tread depth of your pushing device is Okay. If the tyres have reached their wear limit, then the pushing device must no longer be operated.

Check the fixings by visual inspection for damage (cracks and breakages).

Check that all components, especially the bolts, are tight.

Check the connection between the pushing device and your wheelchair.

Check that the brackets on the frame are correctly positioned.

Check the frame and the components of your wheelchair for any damage, (e.g. cracks)

Ensure that the wheelchair user cannot slip off the foot board of the wheelchair.

Use a special fixing tool if necessary.

Check all cables and electrical connections.

Check that the battery is connect correctly and fully charged.

7. Safety instructions – while driving

WARNING!

Make yourself familiar with the product in flat terrain before driving up or down slopes.

Always hold the pushing handles with both hands firmly as otherwise, there is a high risk of an accident through steering error.

Always adapt your speed to your driving capability and to the traffic - / terrain conditions

Use particular caution when approaching stairs, edges, drops or other hazard areas.

When waiting e.g. at a pedestrian crossing, a traffic light, on hills or slopes or at ramps of any type, always activate the brake.

Always follow the road traffic regulations when driving on public roads and footpaths,

Avoid driving on unpaved or loose surfaces (e.g. on loose gravel, in sand, mud, snow, ice or through deep puddles of water).

Avoid abrupt steering actions

Avoid driving in parallel to slopes

Avoid turning on slopes

The driving style and speed should be always adjusted so that the product can be safely stopped at all times.

Driving on stairs is not permitted.

Obstacles e.g. curbs must be run over always frontal / rectangular with very low speed to avoid tipping over and potential injuries. If necessary, tilt the wheelchair.

It must be avoided that any wheelchair components or parts of your body get trapped when driving over or passing obstacles. This could result in falls and serious injuries as well as damage to the pushing device and wheelchair.

Switch off the product immediately when it is not in use to avoid accidental operation or movements caused by accidentally touching the pushbutton.

Switching off helps to preserve the battery charge. Where possible, charge the battery pack after every journey.

8. Warranty

YOUR LEGAL RIGHTS ARE NOT LIMITED BY THIS GUARANTEE.

Sunrise Medical Equipment (Shanghai) Co., Ltd provides a guarantee, as set out in the warranty conditions, for wheelchairs to its customers covering the following.

Warranty conditions:

1. Should a part or parts of the pushing device require repair or replacement as a result of a manufacturing fault within 24 months or for the motor within 3 years after delivery to the customer, then the affected part or parts will be repaired or replaced free of charge. The warranty will only cover manufacturing defects
2. To enforce the warranty, please contact Sunrise Medical Customer Service with the exact details of the nature of the difficulty. Should you be using the wheelchair outside the area covered by the Sunrise Medical customer service agent, repairs or replacement will be carried out by another agency as designated by the manufacturer. The wheelchair must be repaired by a customer service center/dealer designated by Sunrise Medical.
3. For parts which have been repaired or exchanged within the scope of this warranty, we provide a warranty in accordance with these warranty conditions for the remaining warranty period for the wheelchair in accordance with point 1).
4. For original spare parts which have been fitted at the customer's expense, these will have 12 months guarantee, (following the fitting), in accordance with these warranty conditions.
5. Claims from this warranty shall not arise, if a repair or replacement of a wheelchair or a part is required for the following reasons:
 - a. Normal wear and tear, which include batteries, armrest pads, upholstery, tyres, brakes shoes, etc.
 - b. Any overloading of the product, please check the product label for maximum user weight.
 - c. The product or part has not been maintained or serviced in accordance with the manufacturer's recommendations as shown in the user instructions and/or the service instructions.
 - d. Accessories have been used which are not specified as original accessories.
 - e. The wheelchair or part having been damaged by neglect, accident or improper use.
 - f. Changes/modifications have been made to the wheelchair or parts, which deviate from the manufacturer's specifications.
 - g. Repairs have been carried out, before our Customer Service has been informed of the circumstances.

6. This guarantee is subject to the law of the country in which the product was purchased from Sunrise Medical

* Means the Sunrise Medical facility from which the product was purchased.

Liability

If the pushing device is:

- Handled improperly
- Not maintained in accordance with the maintenance schedule
- Commissioned and used contrary to the instructions in this manual
- Repairs or other works are carried out by non-authorized persons, third-party parts are installed or connected without prior agreement with Sunrise Medical, then Sunrise Medical Equipment (Shanghai) Co., Ltd is not responsible for the safety of the pushing device.

Additional Notes For Australia Only:

1. For goods provided by Sunrise medical Pty Ltd in Australia, our goods come with a guarantee by Sunrise Medical that cannot be excluded under Australian consumer law.
2. You are entitled to a replacement or refund for a major failure and compensation for any foreseeable loss or damage.
3. You are also entitled to have the goods repaired or replaced if the goods fail to be of acceptable quality and the failure does not amount to a major failure.
4. The benefits to you given by this warranty are in addition to your other rights and remedies under a law in relation to the goods to which the warranty relates.

9. Delivery

Your new pushing device is delivered fully assembled in a cardboard box. In order to avoid any damage during transportation, loose parts or parts to be fitted, are packed separately in the cardboard box.





Unpacking:

Check the shipping cardboard box for external damage which may have been caused during transportation. Remove all packaging material.

Take the pushing device carefully out of the box and check that it is complete. Check all parts for surface damage, scratches, cracks, dents, distortions and other defects.

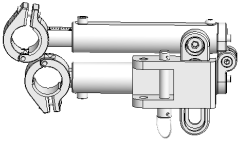
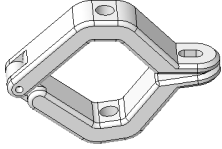
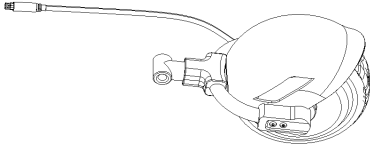
NOTE: Should you find any damage, or if any parts are missing please let us know immediately.

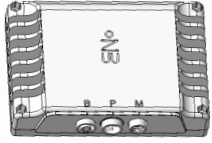
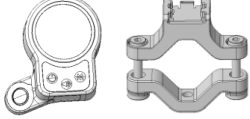
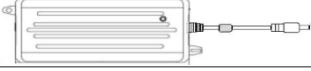
The delivery of the pushing device contains:

Delivery	Description	Quantity
	Docking arm including rotate arm and fold arm.	1
	Limit block.	2
	Drive wheel with integrated motor including brackets.	1
	Backpack with LI-ION 36V/5 Ah battery and motor controller.	1
	LI-ION 36V/5 Ah battery for wheelchair (in the backpack).	1
	Motor controller (in the backpack).	1
	Rear Controller with holder.	1
	Charger 36V/2 A.	1
	Charger cable in compliance with local requirements (UK, Australian, China standards).	1
	Accessories including Velcro, installation tools, bolts and plastic gasket.	1

10. Docking Information

The R10 folding push device easily fits on almost all common manual wheelchairs with the following dimensions:

Box frame or similar frame type with round tubes diameter: 20 - 28 mm.

Seat width: 380 - 520 mm

Rear seat height: 400 - 580 mm

Height between the box frame and the ground (Fig. 10.1): 180 - 220mm

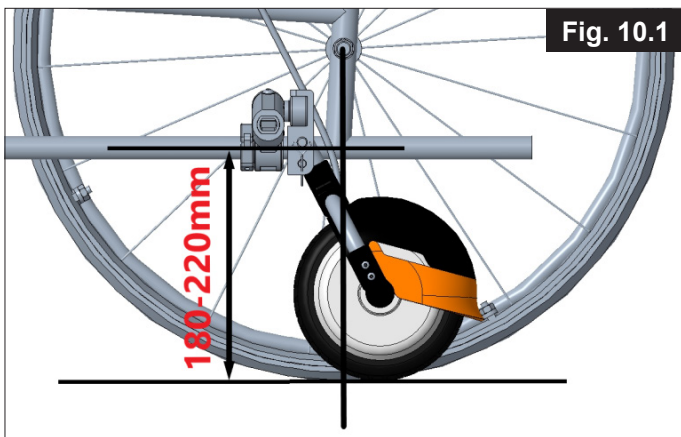

The minimum straight free space of circular tube for install docking arm:

Limit block: used to prevent the docking arm from moving forward. The width is 12mm, so using or not using limit block will affect minimum installation length.

1. If the straight free space of circular tube for install docking arm is $\leq 37\text{MM}$, Suggest canceling the limit block. (Fig. 10.2)

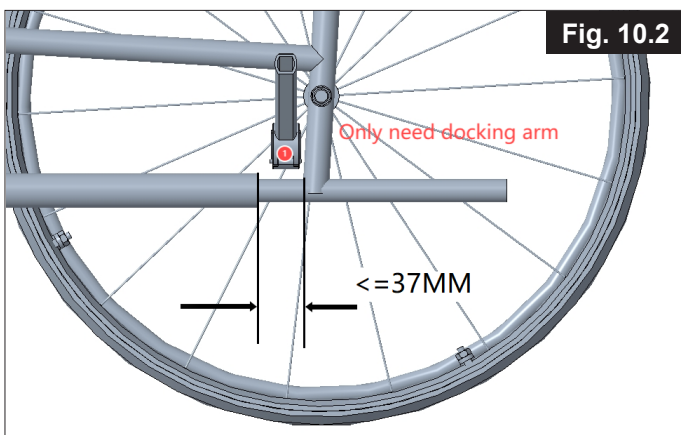

2. The limit block must be used, if the straight free space of circular tube for install docking arm is $>37\text{MM}$. (Fig. 10.3)

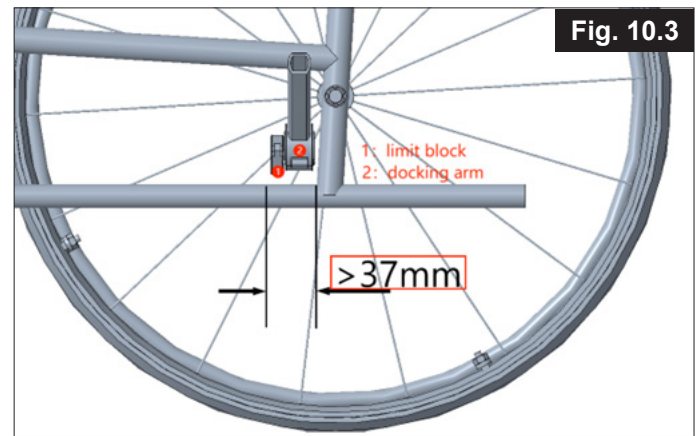

Suggested installation angle: When the angle between the docking arm and the vertical direction is between 25° and 55° (Green section), sufficient friction can be provided. (Fig.10.4)

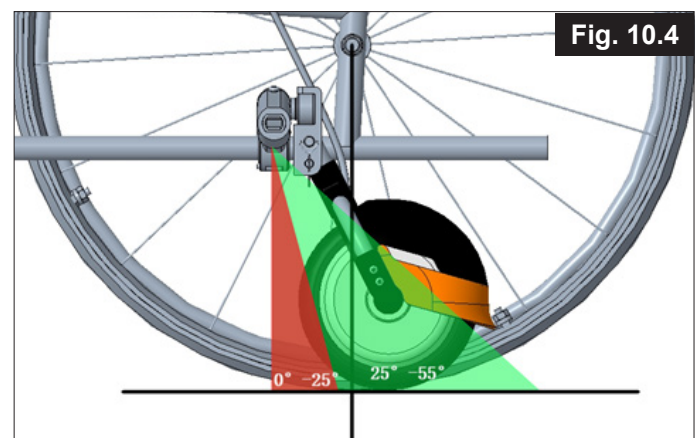

11. Starting up

11.1 Install the push device to the wheelchair

Step 1: Refer to “Empulse R10 Docking Information” to select the appropriate wheelchair and installation location.

Step 2: Expand the Docking arm to the maximum angle, and then install the Docking arm and limit block on the wheelchair. Ensure that the scale markings (M1, M2) on the rotate arm are consistent on both sides. **(Fig.11.1)**

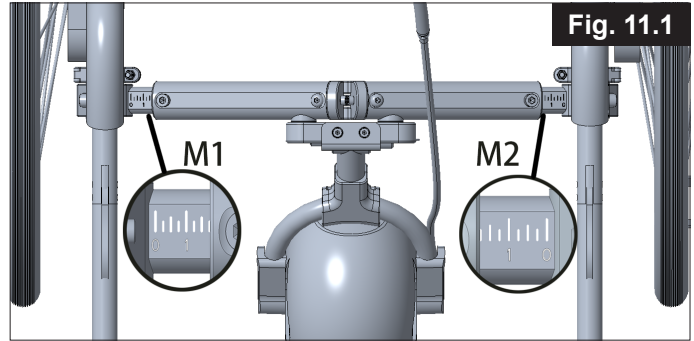

Step 3:

Connect the Drive wheel to the Docking arm. **(Fig.11.2)**

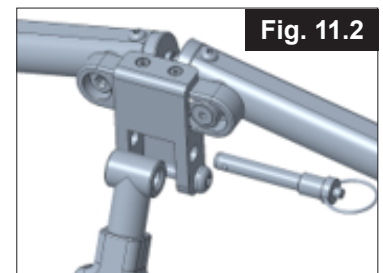

Ensure that the installation holes of the Drive wheel and Docking arm are aligned. **(Fig.11.3)**

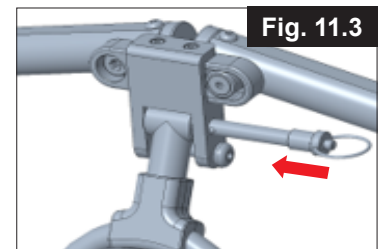

Press the pin button and insert the pin. **(Fig.11.4)**

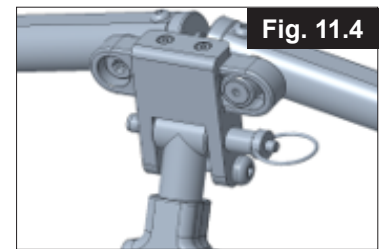

11.2 Install battery (Fig. 11.5)

Step 1: Open the zipper on the back of the backpack.

Step 2: Place the battery charging port (P1) on the right side of the backpack, and thread the power port (P2) through the hole in the upper right corner of the backpack.

Step 3: Put the entire battery into the backpack and zip it up.

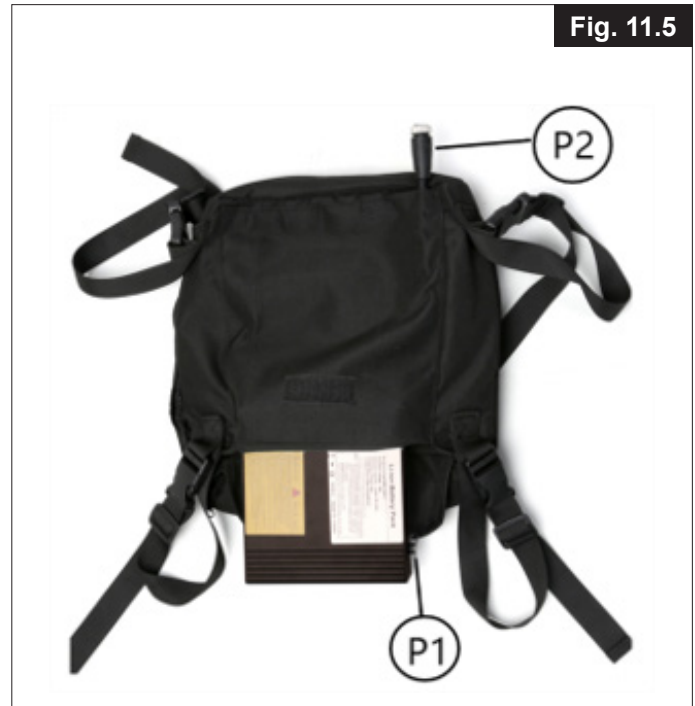

11.2.1 Fitting the backpack onto the wheelchair (Fig.11.6)

Step 1: Unfold the backpack as shown in the picture, with four buckles (T1), Adjust the straps (T2) to the required width for your wheelchair.

Step 2: Secure the four buckles to the four corners of the wheelchair backrest.

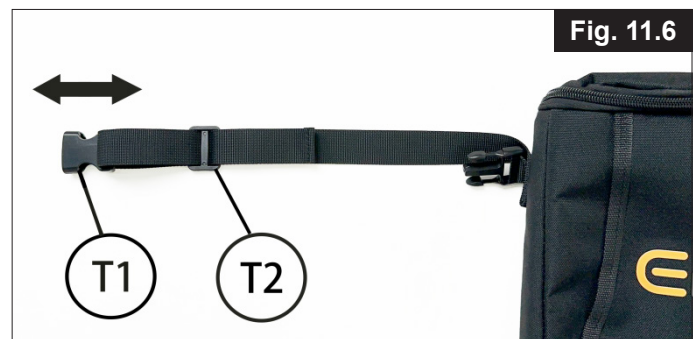

11.3 Mounting the rear controller unit

Step 1: Install the holder horizontally on the right rear armrest, ensuring that the holder opening (H) is facing backwards. Ensure that the holder is level by adjusting the left and right screws (S1, S2). (Fig.11.6)

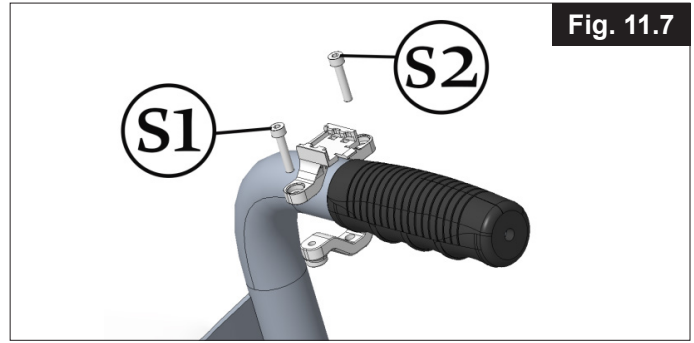

Step 2: Align the rectangular block (L) at the bottom of the rear console with the holder opening (H) and slide it into the opening in the direction of the arrow in the picture. (Fig.11.7)

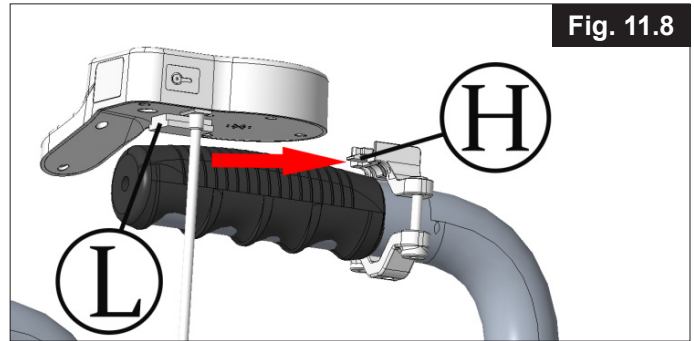

Attention: There is a distance detection sensor (G) in front of the rear controller. Please ensure that there is no obstruction in the front after installation to prevent false detection. (Fig.11.8)

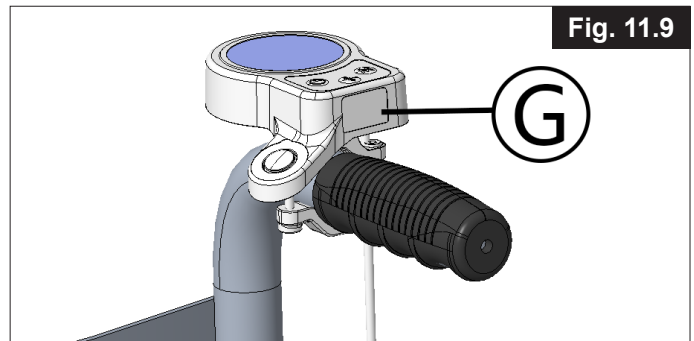

11.4 Connecting cables (Fig.11.9)

Step 1: Align the white arrow side of the rear controller connector (C) with the interface marked as C by the Motor controller, insert it, and tighten the nut.

Step 2: Align the white arrow side of the battery connector (P) with the interface marked as P by the Motor controller, insert it, and tighten the nut.

Step 3: Align the white arrow side of the motor connector (M) with the interface marked as M by the Motor controller, insert it and tighten the nut.

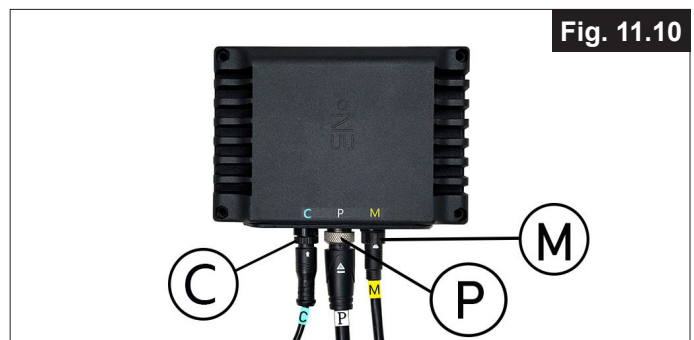

11.5 Run R10 (Fig.11.11)



On/off method: press short, beep once, to turn the R10 on successfully; press long, beep once, to shut down the R10 completely.

Speed setting: press short to change the speed, there are 3 speed levels: 1 - slow, 2 - medium and 3- fast.

LCD display content: Divided into speed level from top to bottom, running time, and remaining power.

- Constant speed assistance: Grasp the push handle, put thumb on the assist button , the wheelchair automatically runs at the set speed. The maximum speed refers to the table below.
- Automatic assistance: Grasp the push handle, push the wheelchair. At this time, R10 will match the power assistance according to the push speed. The faster the speed, the more obvious the power.

After exceeding the maximum speed limit, the assistance will no longer increase. Please refer to the table below for specific speed limit values.

Gear	Automatic assistance limiting maximum speed	Constant speed assistance to set maximum speed
01	1.5 km/h	1.5 km/h
02	3.0 km/h	3.0 km/h
03	4.5 km/h	4.5 km/h

12. Battery/Charge

Before using for the first time, charge the battery fully! The battery can be charged on the wheelchair or separate from the wheelchair.

The battery is placed on the inside of the backpack. To remove the battery, you need to unscrew the connector between the battery and the motor driver and remove it from the inside bag.

How to maintain batteries

1. Charging

- The newly purchased lithium battery needs to be fully charged after using up the remaining battery capacity, and then undergo several full charges to achieve optimal battery performance.
- Use a dedicated lithium battery charger that matches the lithium battery for charging.
- Do not charge at high or low temperatures.

2. Discharge

- Do not over release frequently.
- Charge the battery in a timely manner and do not wait until it is almost dead before charging it.
- Charging at 0-40 ° C and keeping the battery dry

3. Storage and Use

- Do not negatively impact, squeeze, isolate or disassemble the battery without permission
- Do not hit the lithium battery.
- Long term use requires activation charging and discharging once a month.

12.1 Charging the batteries:

Method 1: open the rear controller right cap(A1) to charge the device and connect the charging plug (A3) of the charger. (Fig. 12.1)

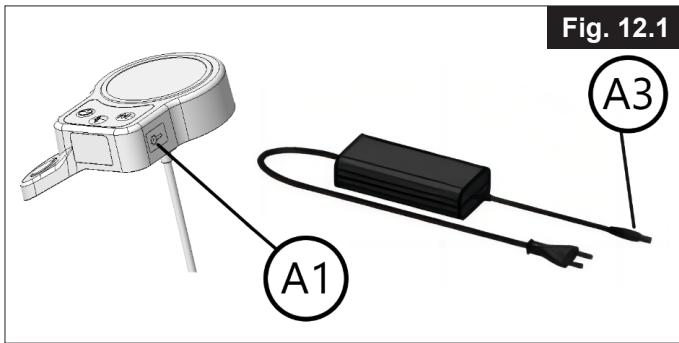

Method 2: Open the battery up cap (A2) to charge the device and connect the charging plug (A3) of the charger. (Fig.12.2)

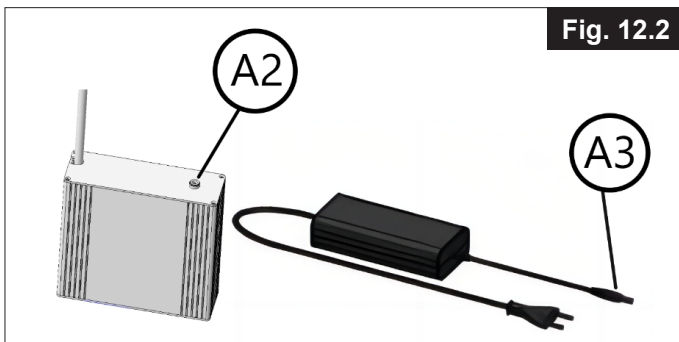

Then connect the charger to the socket using the mains plug. During the charging process, the display on the charger lights up red; as soon as the battery is fully charged, the display lights up green. The charging progress is not shown on the battery itself.

Charging temperature:	0°C to 45°C
Charging time:	approx. 3 - 3.5 hours
Storage:	-20°C to 50°C

We would recommend that you charge the battery after each journey. Before long periods of non-use, the battery should be fully charged. When not being used, the battery should be re-charged every 12 weeks, to avoid damage to the battery. It should only be stored in a dry environment.

After successfully charging, remove the mains plug of the charger from the socket and pull the charging plug out of the charging socket of the battery. Close the charging socket using the end cap, to prevent water ingress and corrosion.

You can obtain information on the state of charge of the battery by rear controller LCD. Assuming you use Method 1 for charging, to do this you must turn on rear controller. After that, the state of charge will be shown on the LCD .

Please also note the information on the rating plate on the battery:

Avoid direct sunlight and high temperatures. The battery must only be used at ambient temperatures between -20 °C and +60 °C.



Keep the battery away from open flames



Cells contain lithium



The battery must not be disposed of as household waste



China RoHS marking: There are dangerous materials used. The number in the logo indicates how many years the product can be used as intended.



Warning: Using an unsuitable battery charger can lead to malfunction and result in the battery having a limited-service life. There is a danger of fire and explosion.



The charger must not be disposed of as household waste



The charger must only be used indoors

You must only use the appropriate charger for this battery from SUNRISE MEDICAL

- When using the battery charger, please note the printed instructions on the battery charger and the following provided information.
- Ensure that the plug is firmly inserted in the socket.
- Never touch plugs with wet hands.
- Do not use the plug of the charger and/or the mains plug if they are wet or dirty. Before inserting it, clean the plug using a dry cloth.
- Do not expose the charger to moisture of any kind during charging (water, rain water, snow, etc.).
- Do not cover the charger during the charging process or place any objects on top of the device.
- Do not carry out the charging process in rooms where moisture may affect the charger.

- Be aware of condensation. If the charger is brought from a cold into a warm room, condensation may form. In this case, refrain from using the charger until all condensation has dissipated. Please note that this may take several hours.
- Never carry the charger by its power cable or the charger cable.
- Do not leave the charger connected to the mains socket any longer than necessary.
- Never tug at the power cable to disconnect the charger from the mains socket.
- Never subject cable and plug to any pressure. Overstretching or bending the cable, pinching a cable or placing heavy objects on a cable or a plug may result in electric shock or fire.
- Avoid short circuits.
- When charging, place the battery on a non-flammable, heat-resistant surface. There should not be any flammable or highly combustible objects near the battery.
- Never leave the battery unattended during charging.
- Damaged batteries must not be recharged or used any further.
- Batteries are not toys and must not be used by children!
- Lay the power cable and the attached charging cable so that nobody can step on it or trip over it and so both cables are not subject to any other harmful effects or stress.
- Do not operate the charger if the power cable, the charging cable or the plugs attached to the cables are damaged. Damaged parts must be replaced immediately by the authorized specialist dealer.
- Do not use or disassemble the charger when it has received a hard blow or was dropped or damaged in another way. Take the damaged charger to a specialist dealer who has been authorized to perform repairs.
- Original plugs and cables must not be cut off or modified.
- Never attempt to disassemble or modify the charger.



Improper handling can lead to risks such as explosions, overheating or fire. Non-observance of the instructions for use can lead to premature wear or other defects. These instructions must be stored safely.

12.2 Safety information and precautions on how to transport and ship the battery:

WARNING!

Lithium-ion cells are used in the battery. Transport and shipping of the battery are, therefore, subject to all applicable statutory requirements, which must be strictly observed. For instance, a defective battery must never be transported by plane.

If your battery is defective, take it personally to your specialist dealer as shipping lithium-ion batteries by post or other carriers is subject to strict rules and regulations. Once again, we recommend that you contact your specialist dealer.

As transport regulations may change annually, we strongly recommend that you consult your travel operator, airline or shipping line before you set out on your trip in order to learn about the current applicable regulations. A defective battery must not be taken on a plane or put in your luggage.

CAUTION!

If your battery is fitted to the pushing device when being transported, relaxed transport regulations apply in accordance with UN3171.

Make sure you keep the packaging container of the battery in case you need to transport it. Discuss transportation with your specialist dealer prior to shipping.

13. Transportation

The pushing aid is not designed for transport in a vehicle. Therefore, being transported while sitting in a wheelchair with a pushing aid attached is not permitted.

⚠ WARNING!

When transporting in a vehicle, do NOT remain seated in the wheelchair with the pushing device fitted. Always use a properly secured vehicle seat.

The product and all its components must be secured during transport so that they are not damaged (e.g. by falling over) and do not become any risk to other people. In this case the pushing device can remain on the wheelchair. The wheelchair can still be folded, even with the pushing device fitted (in so far as this wheelchair is able to fold). The procedure for folding/unfolding is described in the user instructions from your wheelchair manufacturer.

⚠ CAUTION!

When transporting make sure that the cables are not caught up, become kinked or otherwise damaged. The pushing device may not be used with damaged cables.

Disassembly for transportation

For transportation, the pushing device can be removed without the need for tools. (Fig. 13.1)

Step 1: Loosen the rear controller interface (C) and unplug it.

Step 2: Loosen the motor interface (M) and unplug it.

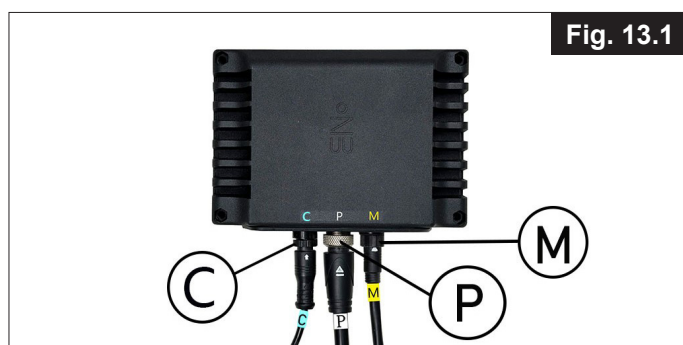

Step 3: Remove the pin between the Drive wheel and Docking arm and remove the Drive wheel.
How to remove pin (Fig.13.2): press the button (B1) and pull the ring (B2) to the right at the same time.

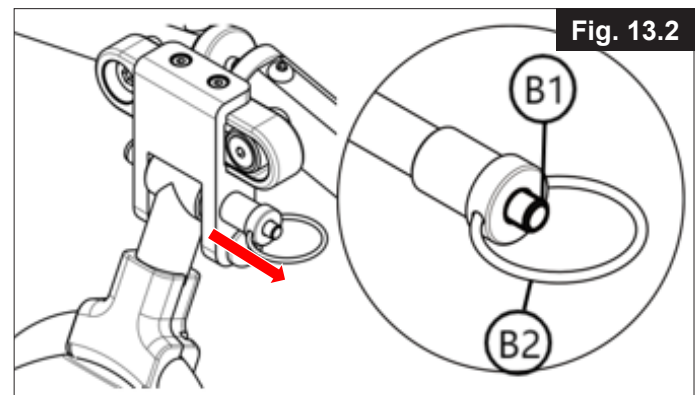

Step 4: Slide the rear control sequentially, remove it from the holder seat, and place the rear controller in the backpack.

Step 5: Release the clips fixed to the four corners of the wheelchair and remove the back pack.

Step 6: Fold the wheelchair and use the velcro strap (S) (Fig.13.3) in the spare parts package to secure the wheelchair to the rear armrest together. Fold the wheelchair and use the velcro strap (S) in the spare parts package to secure the wheelchair to the rear armrest together, to prevent wheelchair unfolding during transportation.



14. Safety:

14.1 Never leave the pushing device unattended, whether it is switched on or switched off.

14.2 Please switch off R10 to use when there is no load.

14.3 When going downhill, please switch off R10 or use the 1st gear to go downhill when R10 is switched on.

14.4 When going uphill, please don't switch off R10 in the middle of the slope or brake in the slope

14.5 In order to be able to go up or down slopes safely, strongly recommend the use of drum brakes.

15. Maintenance

The R10 pushing device is low maintenance. We recommend that the R10 is checked by a dealer every 2 years.

Before any maintenance is started, disconnect the battery and remove it.

Maintenance plan	
	after 24 months
Functionality test und safety check of the docking system (pushing device and wheelchair)	X
Visual check of the docking system, the backpack fixing for damage (tears, distortions, etc.)	X
Visual check of the wheelchair frame, the backrest tubes for damage (tears, distortions, dents, etc.)	X
Check the tyres (profile depth, tears, damage; and replace if necessary)	X
Check all cables and plug connections	X

16. Frequency of Service

Servicing:

If you have any questions or require any help, please contact your authorized Sunrise Medical dealer.

Depending on how much you have used your pushing device, we recommend that you take it to your dealer at least every 2 years, to have your pushing device inspected by trained personnel.

17. Tyre maintenance

The pushing device is fitted with a 6" drive wheel with a solid tyre. Make sure that the tyres have sufficient tread, as this will significantly affect the driving characteristics. When the tyre is worn (see Fig.A and Fig.B) it must be replaced by an authorised dealer.

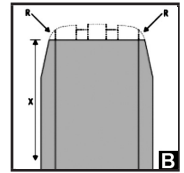
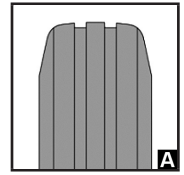

18. Cleaning/Hygiene

The pushing device should be cleaned regularly and after each bigger journey with commercially available household cleaning agents. If needed only use a little water.

The pushbutton, display and battery may only be cleaned by wiping with a damp (not wet) cloth. The drive wheel can be cleaned with a soft sponge or a soft brush.

The docking pins at the wheelchair and the docking system can be cleaned with water, a soft sponge or a soft brush (recommended after each ride).

CAUTION!

Never use steam or high pressure to clean the product.

Never use any abrasive cleaning agents or aggressive, acidic cleaners.

Make sure that water will not get into contact with the electrical connectors.

Hygiene when being reused:

When the pushing device is to be reused, it should be prepared carefully, and be wiped and treated with spray disinfectant on all surfaces which could come into contact with the user. If you need to do this quickly, you must use a liquid, alcohol based disinfectant suitable for medical products and devices. Please pay attention to the manufacturer's instructions for the disinfectant you are using.

19. Disposal / Recycling of materials

Materials Used:

In the following section, there is a description of the materials used on the pushing device, in view of the disposal or recycling of the pushing device and packaging. There may also be special local regulations in force with regard to disposal or recycling, these must be taken into account when disposing of your pushing device. (This can include the cleaning or decontamination of the pushing device prior to disposal).

Aluminium: Docking arm, motor controller box

Steel: Screws

Stainless Steel: Docking pin

Plastic: holder, plug, charger, rear controller box, fender

Rubber: Tyres

Polyester: Backpack

Packaging: Made of soft polyethylene, cardboard

Battery: Lithium-Ion battery (hazardous product)

Please see battery section for more detailed information.

NOTE: Disposal or recycling should be done through a licensed agent or authorized place of disposal. Alternatively, your pushing device may be returned to your dealer for disposal.

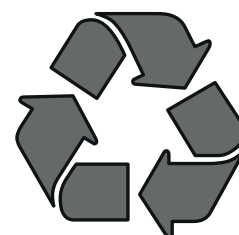

20. Name plate

The nameplate is located on the frame as well as on a label in the owner's manual. The nameplate indicates the exact model designation and other technical specifications. Please provide the following pieces of information whenever you have to order replacement parts or to file a claim:

As we are committed to continually improving the construction of our wheelchairs and pushing devices, product specifications may vary slightly from the examples illustrated. All weight/dimensions and performance data are approximate and is provided solely for guidance.

All pushing devices must be used in accordance with the manufacturer's guidelines.





R10 Product Name/SKU Number.

 Maximum safe slope, depends on wheelchair/ add-on bike setting, posture and physical capabilities of the user.

 Load Maximum.

 Directions for use

 Max speed.

 Electrical voltage / V=Volt.

 Motor performance

 Cells contain lithium

 Must not be disposed of as household waste

 Serial number

 This symbol means Medical Device

 Manufacturer's address.

 XXXX-XX-XX Date of manufacture.



ISO 7010-M002
Instruction manual/booklet must be read!

21. Torque

- The recommended torque value for connecting the rotate arm to the frame tube is 3 Nm
- The recommended torque value for connecting the rotate arm to the fold arm is 3 Nm

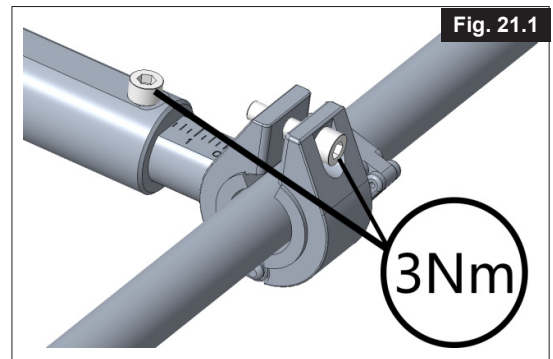

- The recommended torque value for connecting the limit block to the frame tube is 3 Nm

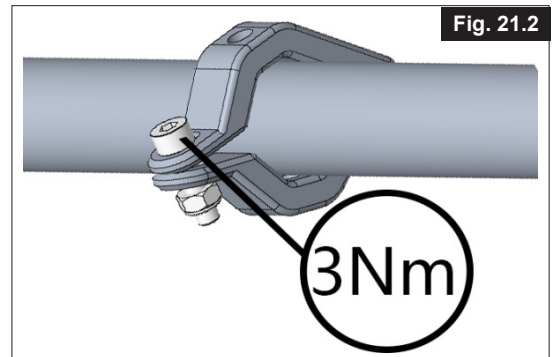

- Motor shaft fixing screw recommend torque 5 Nm

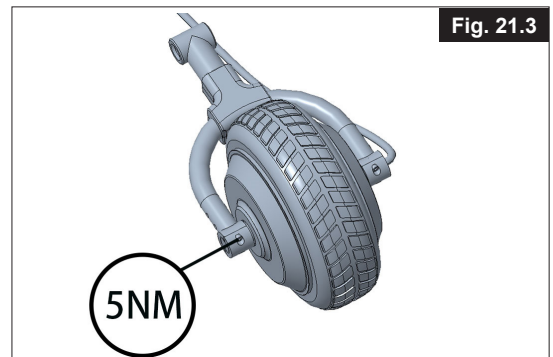

- The recommended torque value for connecting the rear control holder to the circular tube of the rear armrest is 3 Nm

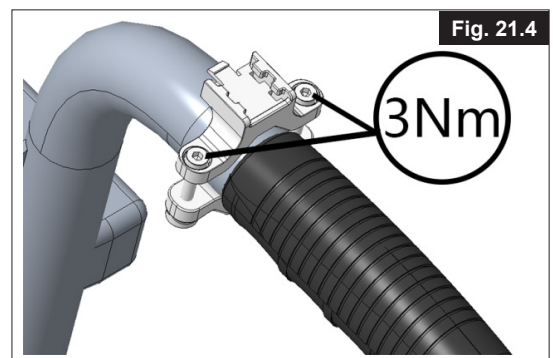

- Fender fixing screw recommend torque 5 Nm

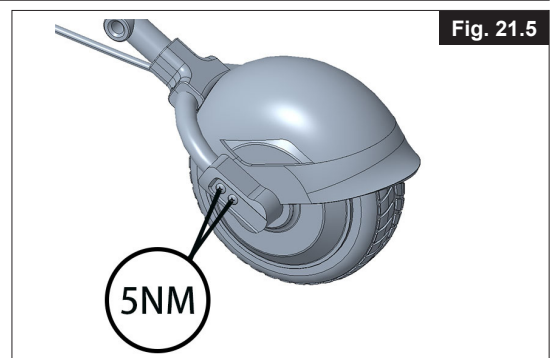

22. Technical data

General data:	
Battery	36 V, 5 Ah Li-Ion
Operating Voltage:	36 Volt
Range:	up to 12 km*
Speed, can be pre-selected:	3 levels (1.5/ 3./ 4.5 kph)
Climbing power:	8°
Max user weight / load:	130kg
Total weight:	6.9kg
Weight of drive unit:	3.7 kg
Weight of battery pack:	1.2 kg

Motor data:	
Rated voltage	36 Volt
maximum current	15 A
Continuous rated power	250 W
Maximum torque	45 Nm
Protection Rating	IP54
Wheel size	6"
Motor noise	max. 50 +/-5 dbA at 1 m distance
Motor temperature (normal operation)	max 41°C
Warranty	3 years

Battery data:	
Rated voltage	36 Volt
Capacity (nominal charge)	5 Ah
Electrical power	180 Wh
Discharge current	15 A (continuous)
Charging time	2.5 - 3 h (approx. at 2 A charging current)
Temperature in normal operation	max. 41°C
Charging temperature range	0°C - 45°C
Operating temperature	-20°C to 60°C
Storage temperature range	-20°C to 50°C
Protection Rating	IP54
Warranty	2 years
Functions	DC2.1 charging port

Charger data:	
Input	100-240V AC
End-of-charge voltage / current	42V / 2A
Surface temperature	up to 50°C

Drive controller data:	
Rated voltage	36 Volt
Maximum current	15 A
Nominal current	7 A
Protection Rating	IP65

Rear controller data:	
Displays	State of remain power (LCD)
	Drive level (LCD Arabic numerals 1,2,3)
Function	Selection of drive levels 1, 2, 3
Protection Rating	IP54

*The testing environment is in level 3, using the Assist button, on flat ground, with a load capacity of 115KG. Depending on the wheelchair – pushing device combination values can vary e.g. surface conditions, user weight, driving capability, add-on weight, topography.

23. Problem solving

Problem	Check		Solution
R10 cannot be switched on	Battery connected properly	no	Plug in properly
	Rear Controller connected properly	no	Plug in properly
	Battery switched on	no	Switch on
	Battery charged	no	Charge
	Problem still present	yes	Contact dealer

R10 doesn't move	R10 switched on	no	Switch on
	Cable plugged in properly	no	Plug in properly
	Battery discharged	yes	Charge
	Drive wheel on the floor	no	Unhook drive wheel
	Drive wheel has traction	no	Contact dealer
	Problem still present	yes	Contact dealer

Battery cannot be charged	Charger plugged in correctly	no	Plug in properly
	Device plug is plugged in properly	no	Plug in properly
	Problem still present	yes	Contact dealer
	Incorrect charger	yes	Use the original charger

Battery damaged	The battery must not be opened - notify dealer		
-----------------	--	--	--

LCD display error codes		
Error code	Failure Cause	Solution
E-002	Hall of motor fault	Check if motor plug is damaged, if damaged need to replace the motor. check if motor hall interface stability or if the motor waterproof interface stability. If no, replace the motor controller.
E-008	Motor current detection error	Contact dealer to replace the motor controller.
E-013	Motor fault	Replacing motor.
E-016	Motor mos fault	Contact dealer to replace the motor controller.
E-020	Battery power detection is incorrect	Check if the battery is damaged, contact dealer to replace the motor controller.
E-040	15 voltage malfunction	Contact dealer to replace the motor controller.
E-021	Instrument communication failure	Contact dealer to replace a motor controller and rear controller.
E-025	The grip detection	Contact dealer to replace the rear control.
E-027	The thumb button is abnormal	Contact dealer to replace the rear control.

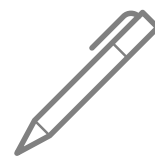





Sunrise Medical Equipment
(Shanghai) Co., Ltd
Cross Region Plaza,
899 Lingling Road,
Xuhui District,
Shanghai 200030
Tel.: (86) 21-644-70011
www.sunrisemedical.cn

Sunrise Medical Australia
11 Daniel Street
Wetherill Park NSW 2164
Australia
Ph: +61 2 9678 6600
E: enquiries@sunrisemedical.com.au
www.SunriseMedical.com.au



Guangzhou ZUBU
Medical Technology Co.,Ltd
11th Floor,
Building 5,
No. 2 Fangda Road,
Huangpu Distract,
Guangzhou/China



OM_Empulse R10_EU_EN_
Rev.A_2024-05-31